

# Product Data Sheet

## May 2014

# Armourplan Standing Seam Profile

## PVC Extrusion

### Product Details

<b>Material</b>	PVC
<b>Length</b>	2000mm
<b>Height</b>	30mm
<b>Width</b>	41mm
<b>Colour</b>	Mid Grey / Slate Grey
<b>Product Number</b>	48002000 / 49002000



### Introduction

Armourplan PVC Standing Seam Profile is a preformed profile used to simulate a metal standing seam joint. The profile is manufactured from PVC and is hot air welded to the installed Armourplan Membrane at a layout specified by the client.

### Features & Benefits

- Cost effective standing seam imitation
- Quick and easy installation
- Attractive roof finish

### Installation

1. Mark out the position of the standing seam profiles across the completed roof area and pull a string/chalk line to achieve a straight edge.
2. Tack weld the standing seam profile on to the completed roof to hold into position.
3. Option 1 – Fully hot air weld each flange of the profile to the roof surface
4. Option 2 – Tack weld the profile to the roof at 200mm centres along each edge of the profile flange. The tack welds should be staggered.
5. Allow a 2mm gap between the end of each profile for expansion / drainage.
6. Option - At the end of the line of profiles install a small section of Armourplan membrane over the end of the profile by hot air welding to the cut end.



01257 488 000

polymeric.sales.uk@iko.com

polymeric.technical.uk@iko.com

**Tel:** 01257 488 000

**Sales:** [polymeric.sales.uk@iko.com](mailto:polymeric.sales.uk@iko.com)

**Technical:** [polymeric.technical.uk@iko.com](mailto:polymeric.technical.uk@iko.com)

## Technical Specification

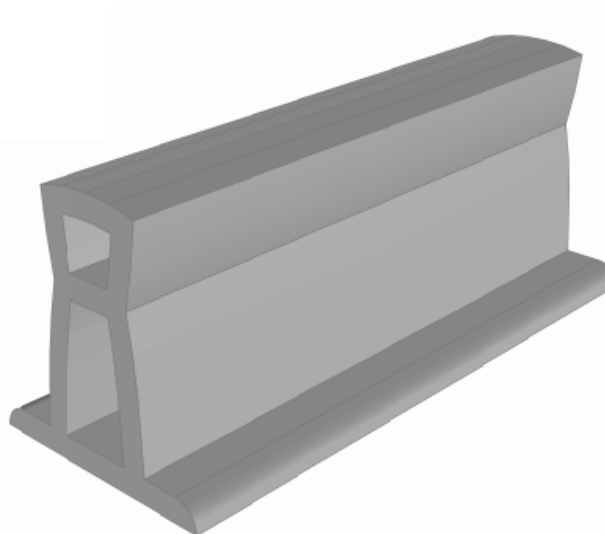
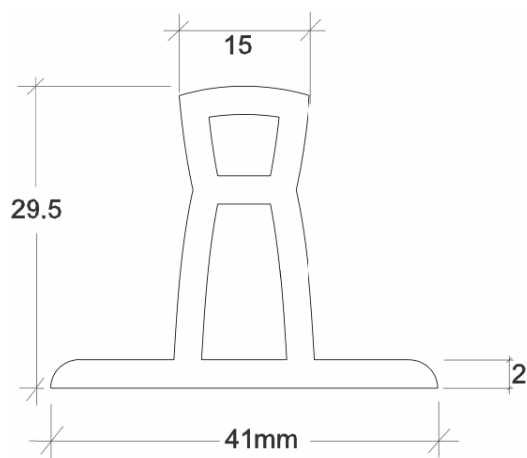

## Storage

Armourplan Standing Seam Profiles should be kept dry. They should be stored raised off the surface of the roof and covered with a suitable waterproof layer.

## Further Product Information

Full product literature, health & safety and technical sheets are available as downloads from our website: [www.ikopolymeric.com](http://www.ikopolymeric.com) or on request by email: [polymeric.marketing@iko.com](mailto:polymeric.marketing@iko.com)

Whilst every care is taken to see that the information given in this literature is correct and up to date it is not intended to form part of any contract or give rise to any collateral liability, which is hereby specifically excluded. Intending purchasers of our materials should therefore verify with the company whether any changes in our specification or application details or otherwise have taken place since this literature was issued.

Company Registered in England No. 2678296 – Registered Office: Appley Lane North, Appley Bridge, Wigan, Lancashire, WN6 9AB



NSFPlus

**IKO Polymeric**  
Coney Green Road, Clay Cross  
Chesterfield, S45 9HZ

**Tel:** 01257 488 000  
**Sales:** [polymeric.sales.uk@iko.com](mailto:polymeric.sales.uk@iko.com)  
**Technical:** [polymeric.technical.uk@iko.com](mailto:polymeric.technical.uk@iko.com)