

## IKO PLC

Appley Lane North  
Appley Bridge  
Wigan  
Lancashire WN6 9AB  
Tel: 01257 256888  
e-mail: technical.uk@iko.com  
website: www.ikogroup.co.uk



Agrément Certificate  
**03/4009**  
Product Sheet 1

## PERMATEC HOT MELT ROOFING AND WATERPROOFING SYSTEMS

### PERMATEC ECOWRAP HOT MELT ROOFING SYSTEM

This Agrément Certificate Product Sheet<sup>(1)</sup> relates to the PermaTEC EcoWrap Hot Melt Roofing System, for use as a waterproofing layer in protected flat roofs (including zero fall), inverted roofs and blue roofs.

(1) Hereinafter referred to as 'Certificate'.

#### CERTIFICATION INCLUDES:

- factors relating to compliance with Building Regulations where applicable
- factors relating to additional non-regulatory information where applicable
- independently verified technical specification
- assessment criteria and technical investigations
- design considerations
- installation guidance
- regular surveillance of production
- formal three-yearly review.



#### KEY FACTORS ASSESSED

**Weathertightness** — the system will resist the passage of moisture into the building (see section 7).

**Properties in relation to fire** — the use of the system can enable a roof to be unrestricted under the national Building Regulations (see section 8).

**Resistance to wind uplift** — the system will resist the effects of any wind suction likely to occur in practice (see section 9).

**Resistance to mechanical damage** — the system will accept the limited foot traffic and loads associated with installation and maintenance, and the effects of thermal or other minor movement likely to occur in service (see section 10).

**Durability** — under normal service conditions, the system will remain waterproof for the design service life of the roof in which it is incorporated (see section 12).

The BBA has awarded this Certificate to the company named above for the system described herein. This system has been assessed by the BBA as being fit for its intended use provided it is installed, used and maintained as set out in this Certificate.

On behalf of the British Board of Agrément

*Claire Curtis-Thomas*

Date of Seventh issue: 24 May 2019

John Albon

Claire Curtis-Thomas

Originally certificated on 24 September 2003

Chief Scientific Officer

Chief Executive

*The BBA is a UKAS accredited certification body – Number 113.*

*The schedule of the current scope of accreditation for product certification is available in pdf format via the UKAS link on the BBA website at [www.bbacerts.co.uk](http://www.bbacerts.co.uk)*

*Readers are advised to check the validity and latest issue number of this Agrément Certificate by either referring to the BBA website or contacting the BBA direct.*

*Any photographs are for illustrative purposes only, do not constitute advice and should not be relied upon.*

#### British Board of Agrément

Bucknalls Lane  
Watford  
Herts WD25 9BA

©2019

tel: 01923 665300  
[clientservices@bbacerts.co.uk](mailto:clientservices@bbacerts.co.uk)  
[www.bbacerts.co.uk](http://www.bbacerts.co.uk)

# Regulations

In the opinion of the BBA, the PermaTEC EcoWrap Hot Melt Roofing System, if installed, used and maintained in accordance with this Certificate, can satisfy or contribute to satisfying the relevant requirements of the following Building Regulations (the presence of a UK map indicates that the subject is related to the Building Regulations in the region or regions of the UK depicted):



## The Building Regulations 2010 (England and Wales) (as amended)

Requirement:	B4(2)	External fire spread
Comment:		The system, when used with suitable surface protection, can enable a roof to be unrestricted under this Requirement. See section 8 of this Certificate.
Requirement:	C2(b)	Resistance to moisture
Comment:		The system will enable a roof to satisfy this Requirement. See section 7.1 of this Certificate.
Regulation:	7	Materials and workmanship (applicable to Wales only)
Regulation:	7(1)	Materials and workmanship (applicable to England only)
Comment:		The system is acceptable. See section 12 and the <i>Installation</i> part of this Certificate.



## The Building (Scotland) Regulations 2004 (as amended)

Regulation:	8(1)(2)	Durability, workmanship and fitness of materials
Comment:		The use of the system satisfies the requirements of this Regulation. See sections 11.1 and 12 and the <i>Installation</i> part of this Certificate.
Regulation:	9	Building standards applicable to construction
Standard:	2.8	Spread from neighbouring buildings
Comment:		The system, when used with suitable protection, can be regarded as having low vulnerability and enable a roof to be unrestricted with reference to clause 2.8.1 <sup>(1)(2)</sup> of this Standard. See sections 8.1 and 8.2 of this Certificate.
Standard:	3.10	Precipitation
Comment:		The system will enable a roof to satisfy the requirements of this Standard, with reference to clauses 3.10.1 <sup>(1)(2)</sup> and 3.10.7 <sup>(1)(2)</sup> . See section 7.1 of this Certificate.
Standard:	7.1(a)	Statement of sustainability
Comment:		The system can contribute to meeting the relevant requirements of Regulation 9, Standards 1 to 6 and therefore will contribute to a construction meeting a bronze level of sustainability as defined in this Standard.
Regulation:	12	Building standards applicable to conversions
Comment:		All comments given for the system under Regulation 9, Standards 1 to 6 also apply to this Regulation, with reference to clause 0.12.1 <sup>(1)(2)</sup> and Schedule 6 <sup>(1)(2)</sup> . (1) Technical Handbook (Domestic). (2) Technical Handbook (Non-Domestic).



## The Building Regulations (Northern Ireland) 2012 (as amended)

Regulation:	23(a)(b)(i)	Fitness of materials and workmanship
Comment:		The system is acceptable. See section 12 and the <i>Installation</i> part of this Certificate.
Regulation:	28(b)	Resistance to moisture and weather
Comment:		The system will enable a roof to satisfy the requirements of this Regulation. See section 7.1 of this Certificate.
Regulation:	36(b)	External fire spread
Comment:		The system, when used with suitable surface protection, can enable a roof to be unrestricted under the requirements of this Regulation. See section 8 of this Certificate.

## Construction (Design and Management) Regulations 2015

## Construction (Design and Management) Regulations (Northern Ireland) 2016

Information in this Certificate may assist the client, designer (including Principal Designer) and contractor (including Principal Contractor) to address their obligations under these Regulations.

See sections: 3 *Delivery and site handling* (3.1, 3.3 and 3.4) and 14 *Procedure* (14.3) of this Certificate.

# Additional Information

## NHBC Standards 2019

In the opinion of the BBA, the PermaTEC EcoWrap Hot Melt Roofing System, if installed, used and maintained in accordance with this Certificate, can satisfy or contribute to satisfying the relevant requirements in relation to *NHBC Standards, Chapter 7.1 Flat roofs and balconies*.



# Assessment and Technical Investigations

The following is a summary of the assessment and technical investigations carried out on the PermaTEC EcoWrap Hot Melt Roofing System.

## Design Considerations

### 4 Environmental information

- 4.1 The PermaTEC waterproofing membrane compound has a recycled content of 45% by mass of the total product.
- 4.2 The recycled materials are described as limestone filler and ground rubber crumb, the latter manufactured from post-consumer vehicular tyres. Post-consumer material is defined in BS EN ISO 14021 : 2016, and the Waste & Resources Action Programme (WRAP) 'Rules of Thumb' Guide to Recycled Content in Construction Products.
- 4.3 The recycled content has been calculated in accordance with BS EN ISO 14021 : 2016 by expressing the input mass of recycled material as a percentage of the total input mass for the product.
- 4.4 The source and quantity of recycled material added to the product is verified by the BBA as part of post-Certification auditing.

### 5 Use

5.1 The PermaTEC EcoWrap Hot Melt Roofing System is satisfactory for use<sup>(1)</sup> as a waterproofing layer on flat roofs (including zero fall) with limited access in:

- inverted roof specifications
- protected roof specifications
- podium decks and walkways for pedestrian access
- blue roofs.

(1) The use of the system in green roof applications is covered by Product Sheet 3 of this Certificate.

5.2 Pedestrian access roofs are defined for the purpose of this Certificate as those not subject to vehicular traffic.

5.3 Limited access roofs are defined for the purpose of this Certificate as those subjected only to pedestrian traffic for maintenance of the roof covering, cleaning of gutters, etc. Where traffic in excess of this is envisaged, additional protection to the membrane must be provided (see section 10).

5.4 Flat roofs are defined for the purpose of this Certificate as those having a minimum finished fall of between 1:80 and 1:6. For design purposes, twice the minimum fall should be assumed, unless a detailed analysis of the roof is available, including overall and local deflection, direction of falls etc. Zero fall roofs are defined for the purpose of this Certificate as those having a finished fall which can vary between 0 and 0.7°.

5.5 Structural decks to which the system is to be applied must comply with the relevant requirements of BS 6229 : 2018 and must be suitable to transmit the dead and imposed loads experienced in service.

5.6 Imposed loads, dead loads and wind loading are calculated by a suitably experienced and competent individual in accordance with BS EN 1991-1-1 : 2002, BS EN 1991-1-3 : 2003 and BS EN 1991-1-4 : 2005, and their UK National Annexes.

5.7 Drainage systems must be correctly designed and provision made for access for maintenance purposes. Blocked drains can cause waterlogging of the drainage and soil layers, thereby increasing dead loads.

5.8 Insulation materials used in conjunction with the system must be suitable for use within inverted roofs in accordance with the manufacturer's instructions.

5.9 Additional guidance for inverted roof specifications is given in BBA Information Bulletin No 4 *Inverted roofs — Drainage and U value corrections*.

5.10 For zero fall roofs, it is particularly important to identify the correct drainage parts, to ensure that drainage is sufficient and effective. Reference should be made to the appropriate clauses of the Liquid Roofing and Waterproofing Association (LRWA) Note 7 — *Specifier Guidance for Flat Roof Falls*, which generally requires surface drainage falls in most situations.

### 6 Practicability of installation

The system should only be installed by contractors who have been trained and approved by the Certificate holder. Details of these are available from the Certificate holder.

### 7 Weathertightness



7.1 The membrane will adequately resist the passage of moisture into the building and enable a roof to comply with the relevant requirements of the national Building Regulations.

7.2 The system is impervious to water and will achieve a weathertight roof capable of accepting minor movement.

## 8 Properties in relation to fire



8.1 The system, when used in protected or inverted roof specifications, including an inorganic covering listed in the Annex of Commission Decision 2000/553/EC, can enable a roof to be unrestricted under the national Building Regulations.

8.2 The designation of other specifications should be confirmed by:

**England and Wales** — test or assessment in accordance with Approved Document B, Appendix A, clause 1

**Scotland** — test to conform to Mandatory Standard 2.8, clause 2.8.1

**Northern Ireland** — test or assessment by a UKAS-accredited laboratory, or an independent consultant with appropriate experience.



8.3 Exposed areas of the system, when used with one of the surface finishes detailed in Approved Document B, Appendix A, Table A5, part iii (England and Wales) and Technical Booklet E, Table 5.6, part iv (Northern Ireland) (listed below), would be deemed to be unrestricted:

- bitumen-bedded stone chippings covering the whole surface to a depth of not less than 12.5 mm
- bitumen-bedded tiles of non-combustible materials
- sand and cement screed
- macadam.

## 9 Resistance to wind uplift

The system will resist the effects of wind suction likely to occur in service.

## 10 Resistance to mechanical damage

The system can accept the limited foot traffic and light concentrated loads associated with installation and maintenance. Reasonable care should be taken to avoid puncture by sharp objects or concentrated loads. Where traffic in excess of this is envisaged, such as for maintenance of lift equipment, a walkway should be provided.

## 11 Maintenance



11.1 Roofs covered with the system must be the subject of annual inspections and maintenance in accordance with BS 6229 : 2018, Chapter 7, to ensure continued satisfactory performance.

11.2 Maintenance should include checks and operations to ensure that the system and drainage outlets are free from the build-up of silt and other debris, and that protection layers, eg walkways, are in good condition.

11.3 In the event of the system being contaminated by oil, grease or other chemicals, the advice of the Certificate holder must be sought.

11.4 Damage to the system must be repaired as soon as possible (see section 1.5).

## 12 Durability



The PermaTEC EcoWrap Hot Melt Roofing System, when protected and subjected to normal service conditions, will provide an effective barrier to the transmission of moisture for the design service life of the roof in which it is incorporated.

# Installation

## 13 General

13.1 The PermaTEC EcoWrap Hot Melt Roofing System must be installed in accordance with the Certificate holder's instructions and this Certificate, on a dry and frost-free substrate. After rain or snow, the substrate must be allowed to dry before installation can commence. The installer can aid drying by any suitable means approved by the Certificate holder. Once applied, the membrane is not affected by rain, snow or frost.

13.2 To assess the suitability of a substrate to receive the membrane, bond tests must be carried out to ensure that adequate adhesion can be achieved. If bonding problems occur, advice must be sought from the Certificate holder.

13.3 Prior to the application of the membrane, defects in the substrate such as cracks, irregularities and other areas of potential weakness must be repaired using an approved repair mortar, and the substrate cleaned in accordance with the Certificate holder's instructions. Additional membrane may be used to fill minor depressions in the substrate.

13.4 Cementitious substrates must be conditioned with IKO PermaTEC High Penetration Primer or IKO PermaTEC Polymer Primer in accordance with the Certificate holder's instructions and allowed to dry before application of the membrane.

13.5 The membrane is covered by a protective layer immediately after installation, in accordance with the Certificate holder's instructions.

13.6 Detailing must be formed in accordance with the Certificate holder's instructions.

## 14 Procedure

14.1 Blocks of the membrane compound are heated in a mechanically agitated melter, which must have a double jacket containing either air or a heat-transfer mineral oil, and be fitted with thermometers to measure the melt and air/oil temperatures.

14.2 The nominal temperature range for the molten membrane is 160 to 180°C. The temperature of the melt must not exceed 190°C.

14.3 The molten membrane is discharged from the melter into a suitable container and applied to the roof, using a long-handled squeegee for horizontal surfaces and a suitable spreader for vertical surfaces.

14.4 At structural movement joints between 12 and 50 mm (maximum 50% total movement), a proprietary joint system must be installed. The Certificate holder should be consulted for suitable products.

14.5 At all non-monolithic changes in substrate materials, at structural/shrinkage cracks between 3 and 6 mm wide, at structural joints between 6 and 12 mm wide and where minor movement may occur, a reinforcement layer of PermaFLASH-D150 should be applied prior to applying the PermaTEC EcoWrap membrane.

14.6 At all board joints in plywood, calcium silicate and composite metal decks, a reinforcement layer of PermaFLASH-D150 or a minimum 150 mm wide strip of PermaFLASH-R must be applied prior to applying the PermaTEC EcoWrap membrane. The advice of the Certificate holder should be sought.

14.7 The first layer of the molten PermaTEC EcoWrap membrane should have a nominal thickness of 3 mm.

14.8 PermaFLASH-R polyester reinforcing scrim is embedded by lightly brushing it into the first layer of the membrane whilst it is still hot and tacky. The reinforcement overlaps must be at least 75 mm and fully sealed by PermaTEC EcoWrap membrane.

14.9 The second layer of PermaTEC EcoWrap membrane, applied over the top of the reinforcement, should have a nominal thickness of 3 mm.

14.10 The membrane must be protected immediately with the specified PermaGUARD protection layer. This is carried out prior to applying the insulation, water control layer and the protective layer or other specified surface finish (see Figure 1 for typical design specifications).

Figure 1 Typical design specifications

PermaTEC — Typical inverted roof

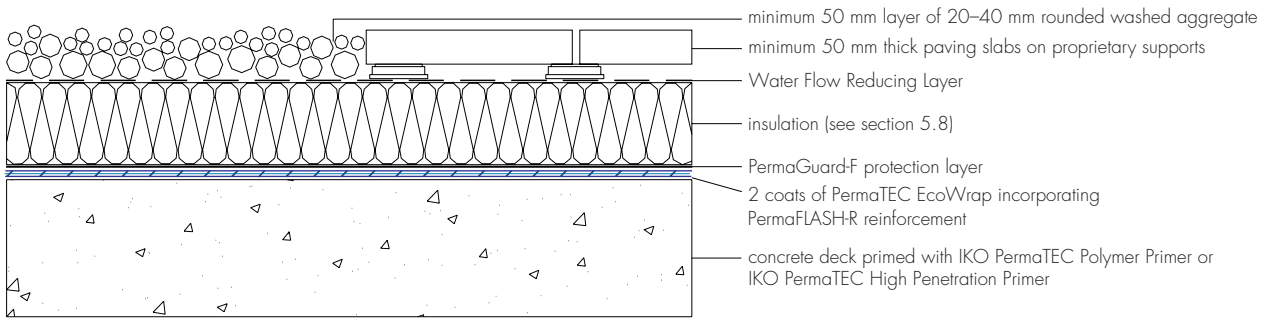

PermaTEC — Typical uninsulated podium deck

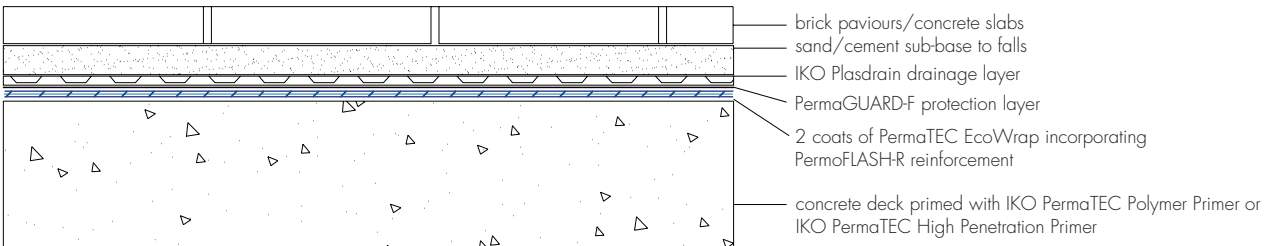

PermaTEC — Rainwater outlet inverted roof

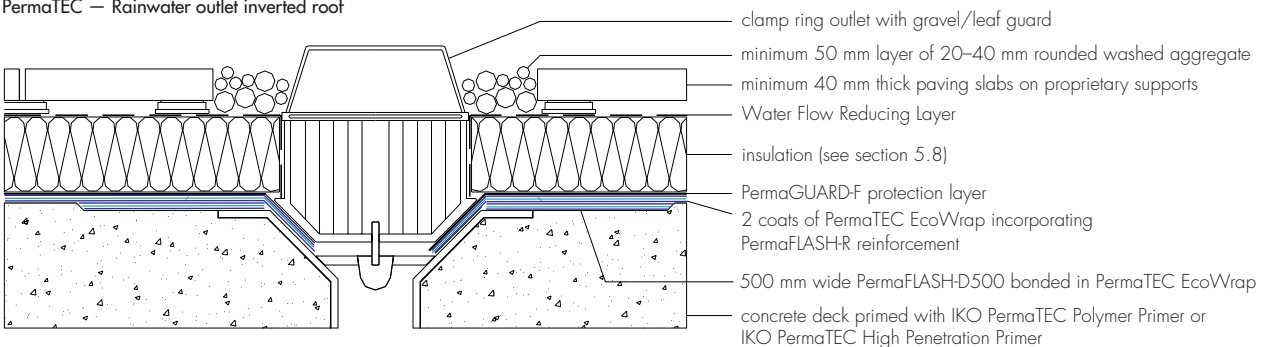

PermaTEC — Cold metal penetration

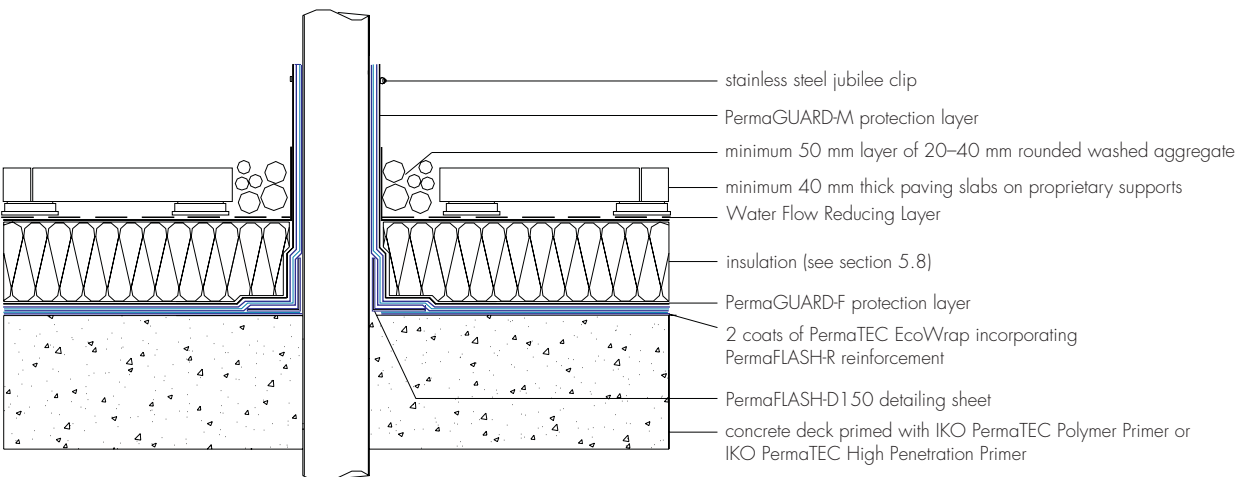
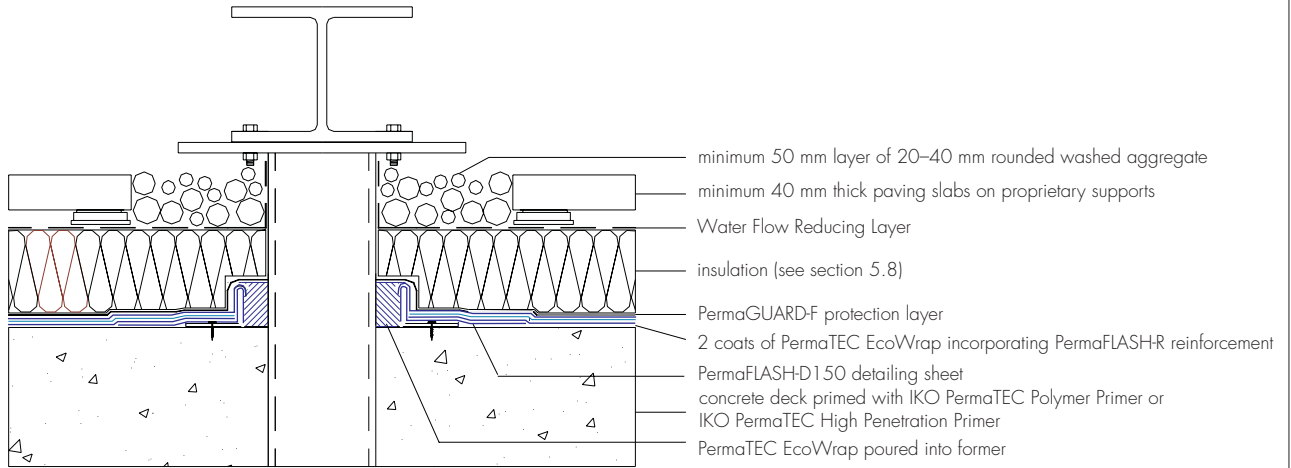
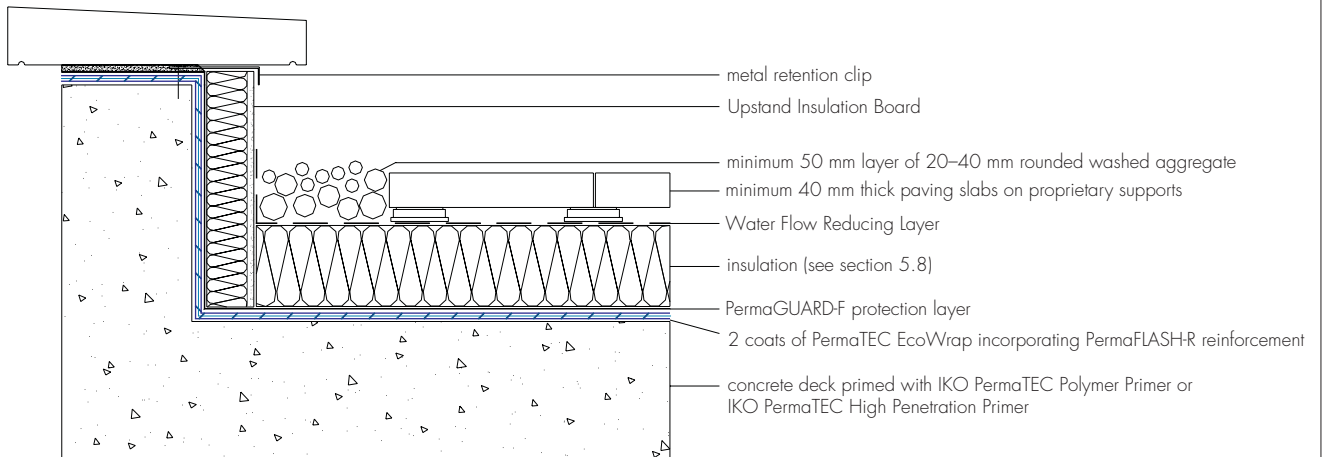

Figure 1 Typical design specifications (continued)

PermaTEC — Pitched pocket



PermaTEC — Typical parapet coping detail



PermaTEC — Typical upstand detail

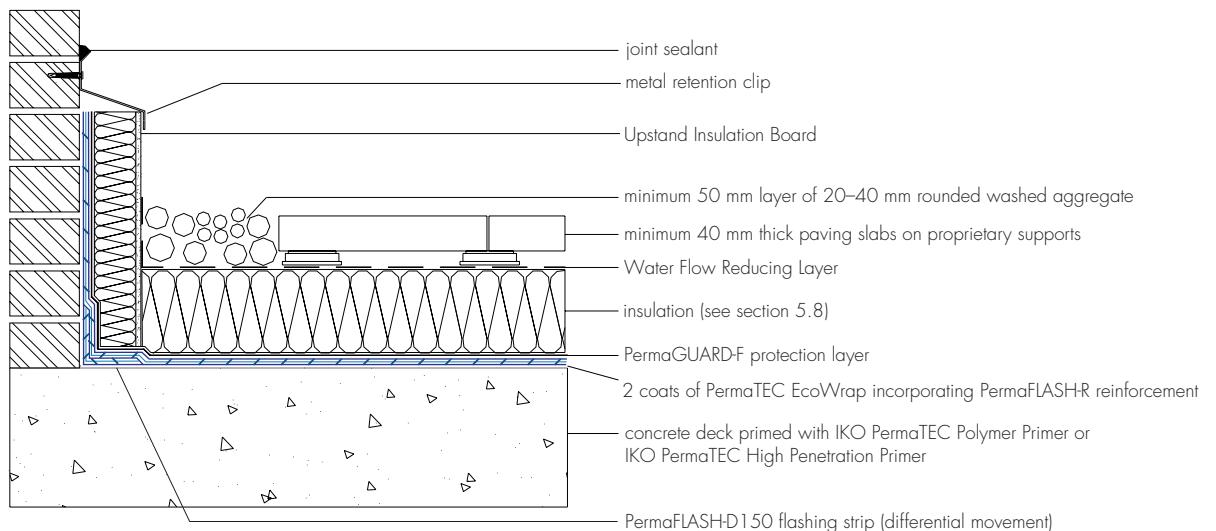



## 15 Repair

15.1 Any damage to the system must be repaired as soon as possible to ensure that the integrity of the waterproofing is maintained. The advice of the Certificate holder should be sought.

15.2 Where maintenance or repair of any of the roof components above the waterproofing system is necessary, care must be taken to avoid damage to the membrane. If damage to the membrane occurs, then it should be repaired in accordance with the Certificate holder's instructions.

15.3 In the event that the system is contaminated by chemicals, oils and greases, the advice of the Certificate holder should be sought.

## Technical Investigations

### 16 Tests

16.1 Characterisation tests were carried out on the PermaTEC EcoWrap compound to establish fines, penetration, flow and resilience.

16.2 Characterisation tests were carried out on PermaFlash-R and Permaflash-D to establish thickness, mass per unit area and tensile properties.

16.3 Tests were conducted on samples of the system and/or system components, and the results assessed to determine:

- water vapour permeability
- watertightness
- low temperature flexibility
- resistance to fatigue
- resistance to dynamic indentation (system including Permaguard-PB protection)
- resistance to static indentation (system including Permaguard-PB protection)
- effect of heat ageing
- effect of exposure to surface water.

### 17 Investigations

The manufacturing process was evaluated, including the methods adopted for quality control, and details were obtained of the quality and composition of the materials used.

## Bibliography

BS 6229 : 2018 *Flat roofs with continuously supported coverings — Code of practice*

BS EN 1991-1-1 : 2002 *Eurocode 1 : Actions on structures — General actions— Densities, self-weight, imposed loads for buildings*

NA to BS EN 1991-1-1 : 2002 UK National Annex to *Eurocode 1 : Actions on structures — General actions— Densities, self-weight, imposed loads for buildings*

BS EN 1991-1-3 : 2003 + A1 : 2015 *Eurocode 1 — Actions on structures — General actions — Snow loads*

NA to BS EN 1991-1-3 : 2003 + A1 : 2015 UK National Annex to *Eurocode 1 : Actions on structures — General actions — Snow loads*

BS EN 1991-1-4 : 2005 + A1 : 2010 *Eurocode 1 : Actions on structures — General actions — Wind actions*

NA to BS EN 1991-1-4 : 2005 UK National Annex to *Eurocode 1 : Actions on structures — General actions — Wind actions*

BS EN ISO 9001 : 2015 *Quality management systems — Requirements*

BS EN ISO 14001 : 2015 *Environmental management systems — Requirements with guidance for use*

BS EN ISO 14021 : 2016 *Environmental labels and declarations — Self-declared environmental claims (Type II environmental labelling)*

BES 6001 : Issue 3.1 *Framework Standard for Responsible Sourcing*

## 18 Conditions

18.1 This Certificate:

- relates only to the product/system that is named and described on the front page
- is issued only to the company, firm, organisation or person named on the front page — no other company, firm, organisation or person may hold or claim that this Certificate has been issued to them
- is valid only within the UK
- has to be read, considered and used as a whole document — it may be misleading and will be incomplete to be selective
- is copyright of the BBA
- is subject to English Law.

18.2 Publications, documents, specifications, legislation, regulations, standards and the like referenced in this Certificate are those that were current and/or deemed relevant by the BBA at the date of issue or reissue of this Certificate.

18.3 This Certificate will remain valid for an unlimited period provided that the product/system and its manufacture and/or fabrication, including all related and relevant parts and processes thereof:

- are maintained at or above the levels which have been assessed and found to be satisfactory by the BBA
- continue to be checked as and when deemed appropriate by the BBA under arrangements that it will determine
- are reviewed by the BBA as and when it considers appropriate.

18.4 The BBA has used due skill, care and diligence in preparing this Certificate, but no warranty is provided.

18.5 In issuing this Certificate, the BBA is not responsible and is excluded from any liability to any company, firm, organisation or person, for any matters arising directly or indirectly from:

- the presence or absence of any patent, intellectual property or similar rights subsisting in the product/system or any other product/system
- the right of the Certificate holder to manufacture, supply, install, maintain or market the product/system
- actual installations of the product/system, including their nature, design, methods, performance, workmanship and maintenance
- any works and constructions in which the product/system is installed, including their nature, design, methods, performance, workmanship and maintenance
- any loss or damage, including personal injury, howsoever caused by the product/system, including its manufacture, supply, installation, use, maintenance and removal
- any claims by the manufacturer relating to CE marking.

18.6 Any information relating to the manufacture, supply, installation, use, maintenance and removal of this product/system which is contained or referred to in this Certificate is the minimum required to be met when the product/system is manufactured, supplied, installed, used, maintained and removed. It does not purport in any way to restate the requirements of the Health and Safety at Work etc. Act 1974, or of any other statutory, common law or other duty which may exist at the date of issue or reissue of this Certificate; nor is conformity with such information to be taken as satisfying the requirements of the 1974 Act or of any statutory, common law or other duty of care.